

Heavy-Duty

Up to 500 lbs./pair*

Adjustable Rod & Shelf Brackets



Cream (CREAM)



White (WH)

1194 Series Heavy-Duty Adjustable Rod & Shelf Brackets

Applications For closet or other storage applications requiring both shelf and closet rod support

Load Rating Up to 500 lbs. per pair*

Mounting Wall

Material 13-gauge steel

Finishes Cream (CREAM) or White (WH): Attractive, long-lasting, corrosion resistant powder coated finishes.

- Features**
- Supports both shelf and closet rod
 - For 11" to 14" deep shelves
 - Brackets can be mounted to any type of wall
 - Use with KV 660, 750 or 770 Series Closet Rods
 - Adjustable bracket allows flexibility in installation
 - Can be used with or without wall cleat
 - Hook depth 3"
 - Available from open stock

*Contact KV customer service for more information.

Standard Pack (10/box. Includes screws.)

Cream (CREAM)	White (WH)
1194 CREAM	1194 WH

1194 Series Heavy-Duty Adjustable Rod & Shelf Brackets

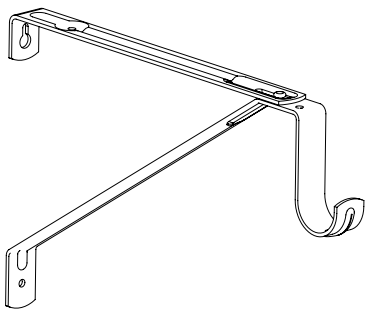

1. Product Name

1194 Heavy-Duty Adjustable Closet Rod & Shelf Bracket.

For closet or other storage applications requiring both shelf and closet rod support.

2. Manufacturer

Knapé & Vogt® Manufacturing Company
2700 Oak Industrial Dr. NE, Grand Rapids, MI USA 49505-6026
616.459.3311 | www.kv.com

3. Product Description

Basic Use: 1194 Heavy-Duty Adjustable Closet Rod & Shelf Bracket are manufactured for closet or other storage applications requiring both shelf and closet rod support. Mounts to any wall type.

Composition and Materials:

1194: 13-gauge steel

Sizes:

1194: 8" high x 11" deep x 1" wide

Finishes: Cream (CREAM) or White (WH).

4. Technical Data

Applicable Standards: Brackets are tested to meet or exceed ANSI performance standards as established by BHMA.

These load limits are intended to be used as general guidelines only, and no warranty — expressed or implied — is made by Knapé & Vogt.

Results were obtained by laboratory testing in accordance with ANSI/ BHMA A156.9-2003 performance standard. (Load ratings based on brackets being mounted on 16" centers. Wider spacing will result in reduced load capacity.) Actual use conditions will typically result in lower load capacity than laboratory conditions.

Representative testing in a fully configured application is the only way to assure proper performance, durability, and safety. Contact KV for verification testing service of your specific application.

Environmental Considerations:

Environment: Excessive humidity, salts, or other chemical agents can corrode the finish and attack metal or plastic components.

Fastening: Inadequate or incorrect fasteners can result in the brackets pulling loose and causing damage.

Alignment: Improper bracket alignment can result in a system that is ineffective and unsafe.

5. Installation

For maximum loading capacity, brackets should be mounted directly to wall studs, which are generally found on 16" centers. Prior to drilling all holes, check to be sure that the bracket is vertically level.

Attach one bracket to wall stud by fastening one #10 x 2" screw through the top mounting hole in bracket. Use a level to position the second bracket at the same height as the first bracket and fasten it to a wall stud using one 2" screw through the top mounting hole.

Center the shelf on the brackets. Fasten a #8 screw through rear most mounting hole on each bracket. Confirm that the shelf fits properly and adjust position of brackets if necessary.

Finish securing the brackets to the wall by fastening #10 x 2" screws through the second wall mounting hole.

Finish securing the brackets to the shelf by fastening a #8 screw through the front mounting hole.

6. Availability and Cost

Availability: Knapé & Vogt (KV) products are available from stocking distributors and through KV Representatives worldwide.

Cost: Current pricing is available from area KV Representatives. Please call for the nearest representative at: 800.253.1561.

7. Warranty

Limited Lifetime Warranty: Knapé & Vogt offers its standard Limited Lifetime Warranty to the initial purchaser of commercial products. This warranty covers defects in materials and workmanship which occur during normal use, and the remedy is limited to repair or replacement of defective products, at KV's option. Certain types of defects and damage are excluded from warranty coverage, costs and expenses are not covered, and additional restrictions apply. A copy of the Limited Lifetime Warranty, with all warranty details, limitations and disclaimers, is available on the Customer Care Connection location at www.kv.com or from KV Customer Service, 2700 Oak Industrial Drive, Grand Rapids, MI 49505, (800) 253-1561.

8. Maintenance

1194 Series Heavy-Duty Adjustable Closet Rod & Shelf Bracket require no maintenance. Inspect for proper fit periodically and adjust when necessary. Replace as required or recommended by application.

9. Technical Services

Knapé & Vogt and area representatives can assist with any application. For further information, or for the name of the representative nearest you, please call Knapé & Vogt Customer Service: 800.253.1561 or visit our website at: www.kv.com.

10. Filing Systems

Additional product information, data sheets, application sheets, and a full catalog are available upon request from Knapé & Vogt.



KNAPE & VOGT.

2700 Oak Industrial Dr. NE
Grand Rapids, MI 49505-6026 USA
1.800.253.1561 | 616.459.3311
Fax: 877.636.3290
www.kv.com

BHMA Knapé & Vogt shelving products follow the ANSI testing standards established by BHMA.

This and other KV literature is available for download at www.kv.com > Resource Library
Knapé & Vogt reserves the right to change product specifications at any time without notice and without incurring responsibility for existing units. This information conforms to editorial style prescribed by The Construction Specifications Institute.
©2016 Knapé & Vogt. KV and the KV logo are trademarks of Knapé & Vogt.

OL2895/1116